

# Foster

Live the Quality

## USER'S MANUAL FOR GAS COOKER HOBS

---

Abstract

**Foster** spa

via M.S. Ottone, 18/20

42041 Brescello (RE) - Italy

tel. +39.0522.687425 - tel. Servizio Assistenza +39.0522.684450

fax +39.0522.686019 - fax Servizio Ricambi +39.0522.962166

e-mail: [service@fosterspa.com](mailto:service@fosterspa.com)

[www.fosterspa.com](http://www.fosterspa.com)

Dear Customer,

We thank you for having chosen a Foster cooker hob.

Your preference is our pride and satisfaction.

In this document are the recommendations and instructions that will enable you to make the best use of the purchased cooker hob and guarantee its best preservation in time. We ask that you take a few minutes to protect the efficiency of the product and for your satisfaction.

With kind regards

**Foster spa**

## Table of Contents



### GENERAL WARNINGS

*General recommendation to be consulted before installation and use of the purchased cooker hob.*

1.	Usage warnings .....	21
2.	Safety warnings.....	22
3.	Warnings for disposal.....	22
4.	Know your appliance.....	23



### INSTALLER INSTRUCTIONS

*They are intended for the qualified technician that will complete appliance installation, commissioning and initial testing.*

5.	First installation .....	24
6.	Positioning in the work top .....	24
7.	Fastening the cooker hob to the cabinet.....	26
8.	Connecting the cooker hob to the gas network.....	29
9.	Room ventilation .....	30
10.	Discharging combustion products (exhaust).....	31
11.	Adapting to different types of gasses.....	31
12.	Adjustment of the minimum.....	33
13.	Electrical connection of the cooker hob.....	33



### USER INSTRUCTIONS

*The indicate usage recommendations, a description of controls and the correct cleaning and maintenance operations for the appliance.*

14.	Cooker hob use.....	34
15.	Cleaning and maintenance.....	37
	Gas cooker hobs summary.....	182



# 1. Usage warnings



This manual is an integral part of this appliance. It is necessary to keep it undamaged and on hand for the entire life cycle of the hob. **We recommend carefully reading this document and all instructions contained within before using the appliance.**

**Installation must be completed by qualified personnel** according to current standards. **This appliance** is intended for domestic type use, and **is conform with CE Directives** currently in force.



The appliance has been manufactured to carry out the following function: **COOKING AND HEATING FOOD, ANY OTHER USE MUST BE CONSIDERED IMPROPER.**

The manufacturer declines any responsibility for uses that are different from those indicated.

- Never use this appliance for heating environments.
- Do not leave packaging material waste unguarded in the household environment.
- Separate the various packaging waste materials and deliver them to the closest selective waste collection centres.



This appliance has a mark pursuant to European Directive 2002/96/EC with regard to waste, electric and electronic appliances (waste electrical and electronic equipment - WEEE). This Directive defines the Standards for the collection and recycling of dismissed appliances valid throughout the territory of the European Union.



**The identification plate**, with technical data, serial number and marking, **is positioned in view under the housing** [Fig. 1].

**THE PLATE MUST NEVER BE REMOVED.**

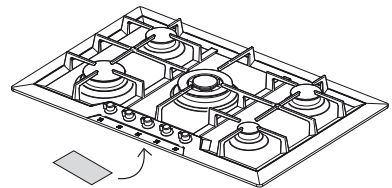

Fig. 1: position of the identification plate

## 2. Safety warnings



In your interest and for your safety, **by law it has been established that installation and service for all electric or gas appliances must be carried out by qualified personnel, according to current regulations and the requirements of local companies supplying gas and electric power.**

- Gas or electric appliances must always be disengaged by competent persons.
- The plug to be connected to the power supply cable and the related socket must be of the same kind and conform to regulations in force.
- The socket must be accessible once the appliance is installed.
- Never detach the plug by pulling on the cord.
- It is mandatory to have an earth connection as per modes foreseen in the electrical system safety standards.
- Do not block the openings and ventilation and heat dispersion slots.



Immediately after installation complete a short test on the appliance following the instructions contained in subsequent pages in this manual. **If it does not operate correctly, disconnect the appliance from the power mains and contact the closest technical assistance centre: NEVER ATTEMPT TO REPAIR THE APPLIANCE.**

During use the appliance becomes very hot. The use of proper thermal gloves is recommended for any type of operation. The appliance is to be used by adult persons. **DO NOT ALLOW CHILDREN TO COME CLOSE OR PLAY WITH IT.**



The manufacturer declines any liability for damages to persons or property, caused by the non observance of the following regulations or resulting from tampering with even a single part of the appliance and using non original spare parts.

## 3. Warnings for disposal

### **OUR CARE FOR THE ENVIRONMENT**

Our products are packaged using non polluting materials, that are therefore compatible with the environment and recyclable. We request your cooperation in making sure that packaging materials are disposed of correctly. Contact your reseller or competent organizations in your area for information about waste collection centres, recycling and disposal.



**DO NOT ABBANDON THE PACKAGING MATERIAL OR PARTS OF IT. THEY MAY CREATE A SUFFOCATION DANGER FOR CHILDREN, ESPECIALLY PLASTIC BAGS.**

Even your old appliance must be disposed of properly, this will contribute to avoiding negative environmental and health consequences, that would occur as a result of improper disposal.



**IMPORTANT:** this appliance cannot be treated as household waste. Deliver the old appliance to the local company that is authorised to collect appliances that are no longer in use. A proper disposal makes an intelligent recovery of precious materials. It is also necessary to cut the cable connecting to the power mains and remove it along with the plug.

## 4. Know your appliance

All drawings relating to the Foster cooker hobs manufactured today, are at the end of this manual, **Gas cooker hobs summary**  [Page 182].

We ask that you recognise the drawing of the cooker hob you have purchased to familiarise with the main technical-functional features.

For research practicality the cooker hobs are distinguished in two macro-families:

- **Traditional built-in cooker hobs:** “8 mm edge”, “Q4 edge” and “semi-flush edge”;
- **Flush built-in cooker hobs:** “flush-mount” edge.

**Regardless of the type of edge**, the first group has a simple traditional built-in hole. The cooker hobs with “flush-mount” edge have a more detailed drawing to enable realisation of the “made to measure” hole, or having a step necessary to house the edge of the cooker hub so it is “flush” with the worktop.

Numbers in correspondence with the burners are present in all drawings. Such numbers identify the type of burner depending on the key below. To know the powers of the burners of the gas cooker hub you purchased, refer to reading the powers table depending on the type of gas used  [Page 182].



## 5. First installation



Do not leave packaging material waste unguarded in the household environment. **Separate the various packaging waste materials and deliver them to the closest selective waste collection centres.**

**In order to remove all manufacturing residues, we recommend cleaning the appliance.**

For further information on cleaning see **Chapter 15**  [Page 37].

## 6. Positioning in the work top



The following interventions require masonry and/or carpentry work and must therefore be completed by a competent technician. Installation can be completed on different materials, such as masonry, metal, solid wood and plastic laminated wood, as long as it is heat resistant (T 100°C).

### 6.1 Installation on the support structure (worktop) of a traditional built-in cooker hob (8 mm edge, Q4 edge, semi-flush edge)



Cut an opening on the top surface of the cabinet with the dimensions and position indicated here below and represented in the drawing [Fig. 2].

The dimensions of the built-in hole are shown in the **Gas cooker hobs summary - models with traditional built-in**  [Page 182], in correspondence of the drawing of the purchased cooker hob.

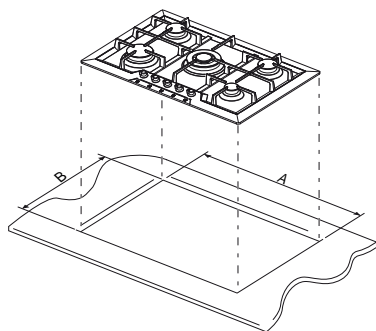

Fig. 2: cutting the hole for the built-in



- The distance of the cooker hob from the back edge must be at least 50 mm;
- The distance of the cooker hob from the walls that exceed worktop height must be at least 100 mm;
- Make sure that there is a minimum distance of 750 mm from the burner to any shelf placed vertically above it;

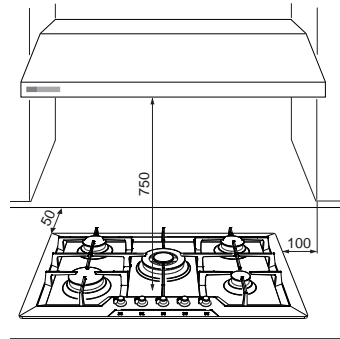



Fig. 3: cooker hob distances

- Make sure that any exhaust appliances installed above the cooker hob are positioned according to the measurements indicated in the hood instructions booklet.



- Carefully position the supplied insulating gasket along the external perimeter of the hole created on the worktop, trying to make it adhere along the entire surface by slightly pressing it by hand [Fig. 4].
- Once these operations have been completed, use the supplied brackets to fasten the hob to the structure. Refer to the “**Fastening the cooker hob to the cabinet**” paragraph  [Page 26].

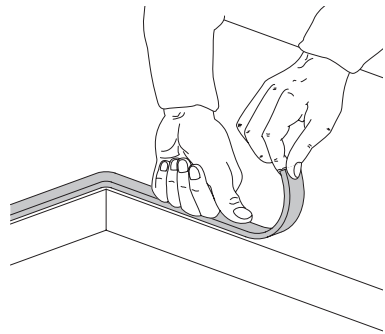



Fig. 4: positioning the insulating gasket

## 6.2 Installation on the support structure (worktop) of a flush built-in cooker hob (flush-mount edge)



This type of appliance requires **milling on the 1.5 mm deep worktop**, which measurements are indicated in the top drawing, identifiable in the section **Gas cooker hobs summary - models with "flush" built-in**  [Page 182]. The step is necessary to house the cooker hub edge so that it is "flush" with the worktop.



- Accurately clean milling.
- Before positioning the top, lay the sealer gasket provided on the entire milling surface [Fig. 5].
- Once these operations have been completed, use the supplied brackets to fasten the hob to the structure. Refer to the **“Fastening the cooker hob to the cabinet”** paragraph [Page 26].

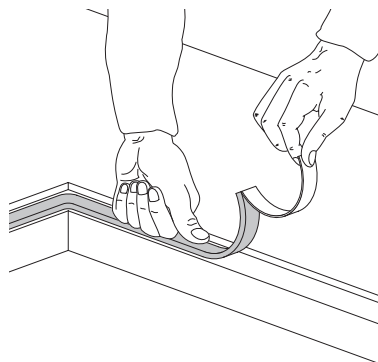

Fig. 5: *positioning the insulating gasket*



A constant light of at least 0.5 mm is envisioned between the external dimensions of the stainless steel platform and the internal dimensions of the lowering that must be respected during assembly. The temperatures that develop during use of the cooker hub induce a slight elongation on the stainless steel platform, therefore, the envisioned light enables avoiding any interferences. With regard to the kitchen worktop, the temperatures induced by the cooker hub - whether in the section and on the contact top - are very contained. We recommend assembling the cooker hubs with flush-mount edge on water-repellent materials.

## 7. Fastening the cooker hob to the cabinet



Fasten the supplied hooks to the brackets under the appliance, as shown here below. The supplied hooks make it possible to fasten to a top whose thickness is between 30 and 40 mm.



### IMPORTANT:

- For fastening this product to the support structure, the use of **mechanical or electric screwdrivers is not recommended** and only moderate pressure must be exerted by hands to the clamping parts.
- The surface under the appliance must be at least 5 mm from the bottom of it and must have **an opening for passing gas and electric conduit that is at least 50x50 mm.**
- **If this product is installed above an oven, it must be equipped with a cooling fan.**





## 7.1 Fixed hooks

They make it possible to fasten the cooker hob using fixing frames pre-set along specific points.



### **Standard edge (8 mm)**

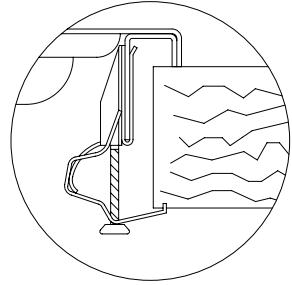
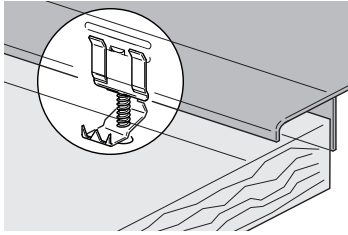

### **Q4 edge (4 mm)**

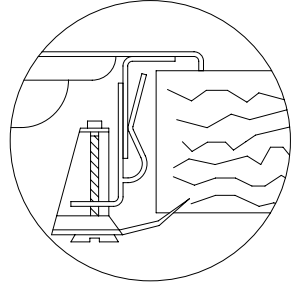
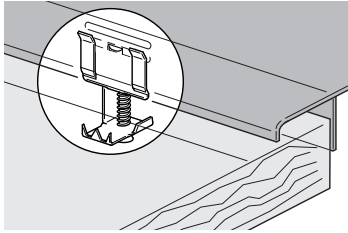

### **Semi-flush edge (3 mm)**

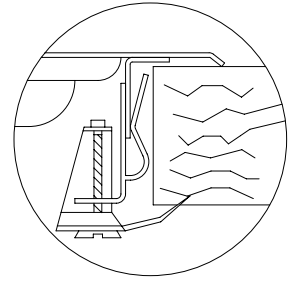
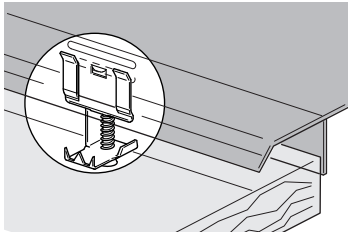

### **Flush-mount edge**

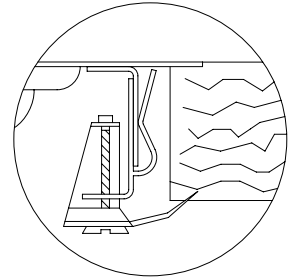
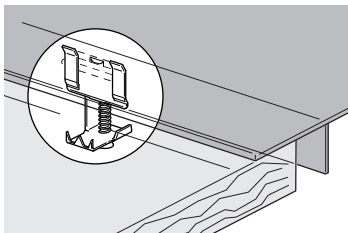



Set hook B in frame A welded to the hob, making sure that it is blocked in the specific holes based on top thickness (for a 30 mm thick top, lock the hook in the the highest hole in the frame; for a 40 mm thick top, block the hook in the lowest hole of the frame).

Rotate tongue CA until it is positioned above the top, then tighten screw D.

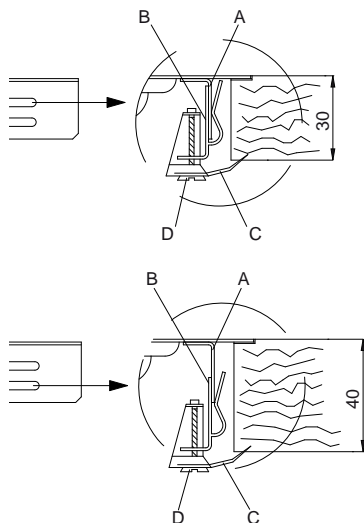

## 7.2 Sliding hooks

Make it possible to fasten the cooker hob without pre-set fastening points.



### Standard edge (8 mm)

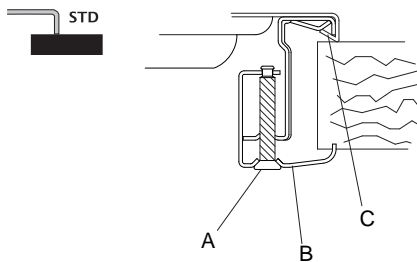
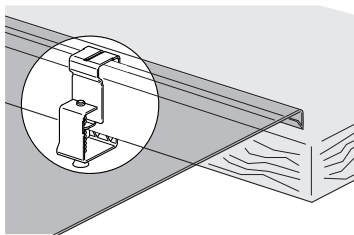

### Flush-mount edge - Q4 (only for S4000 series)

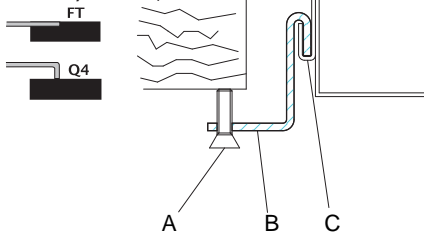
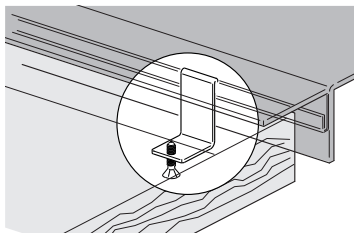

Insert hook B in the sliding guide CA.  
Manually lock the hook using screw A.



### 7.3 Fixed brackets

Make it possible to fasten the cooker hob in pre-set fastening points.



#### Standard edge (8 mm)

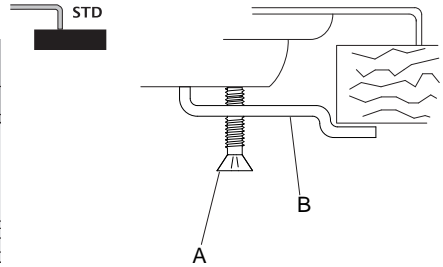
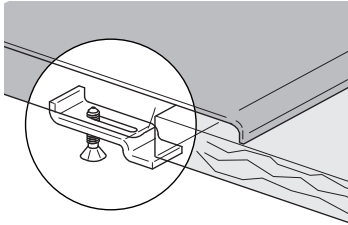

Introduce the bracket B in appropriate top seat.  
Manually lock the bracket using screw A.

## 8. Connecting the cooker hob to the gas network



It is necessary for the gas supply system to conform to local regulations in force.

It is necessary to verify that local distribution conditions (gas nature and pressure) and the appliance adjustment status are compatible.

**IMPORTANT:** If the appliance is installed above an oven, it is necessary to avoid passing the gas tube behind the oven in order to avoid overheating.



**The connection to the gas supply network** can be completed using **rigid copper piping** or **with a continuous flexible steel pipe** on the wall, according to established regulations that are parts of the regulations in force [Fig. 6]. In any case **every pipe connected to the gas supply network must be equipped with a safety interception valve.**

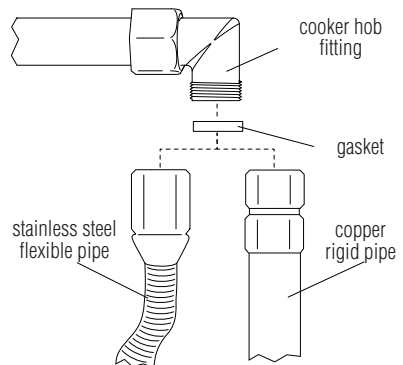

Fig. 6: connection to the gas supply network



**IMPORTANT:** Always place the gasket between the hob fitting and the connection pipe.



- **If using a stainless steel flexible pipe**, it must be installed so that it does not come in contact with any part of the cabinet, but passes through an unoccupied area where its entire length can be inspected. Maximum extension of the flexible pipe must be less than 2 metres.
- The gas fitting is the type with a 1/2" gas ISO R7 tapered thread.



After connecting the appliance to the gas supply network **always verify fittings seal** using a soapy solution.  
**VERIFYING THE SEAL USING NAKED FLAMES IS ABSOLUTELY PROHIBITED.**



**The cooker hob is tested for methane gas G20 (2H) at a pressure of 20 mbar.** For supplying with other types of gas, see the **Adapting to the different types of gas table**  [Page 31]

### 8.1 Connection to liquid gas



Use a pressure regulator and realise connection on cylinder in compliance with the prescriptions established by the current Standards.

**Ensure the supply pressure respects the values indicated in the table Adapting to different types of gasses**  [Page 31]. In this case also, connection must be carried out with copper rigid pipe or with stainless steel flexible pipe with continuous wall.

## 9. Room ventilation



**IMPORTANT:** The appliance can only be installed in rooms that are permanently ventilated, as required by standards in force.



## 10. Discharging combustion products (exhaust)



Discharge of combustion products must be ensured through hoods connected to an efficient natural draught flue, or through a forced exhaust.

An efficient exhaust system requires an accurate design by a specialist that is approved for this work, following positions and distances contained in regulations.



**IMPORTANT:** At the end of the intervention the installer must issue a conformity certificate.

## 11. Adapting to different types of gasses

Gas type	Burner			Rated capacity (KW)	Rated consumption (g/h)	Injector (ø mm)	Min rated capacity (KW)
	Series	No.	Ref.				
LPG GAS G30/G31 28-30/37 mbar	II	2	Auxiliary	1,00	73	0,50	0,52
		3	Semi-quick	1,75	127	0,65	0,52
		4	Quick	2,70	196	0,80	0,90
		5	Triple crown	3,50	254	0,95	1,80
		10	Dual	4,50	328	i 0.46 / and 0.66	i 0.46 / and 0.66
	III	6	Auxiliary	1,10	80	0,52	0,52
		7	Semi-quick	1,75	127	0,65	0,52
		8	Quick	3,00	218	0,85	0,90
		9	Triple crown	3,80	276	0,98	1,80
	AE	11	Auxiliary	1,00	73	0,50	0,52
		12	Semi-quick	1,75	127	0,65	0,52
		13	Quick	3,00	218	0,85	0,90
		14	Dual gear	5,00	364	i 0.46 / and 0.95	i 0.30 / and 1.40



Gas type	Burner			Rated capacity (KW)	Rated consumption (l/h)	Injector (ø mm)	Min rated capacity (KW)
	Series	No.	Ref.				
METHANE GAS G20 20 mbar	II	2	Auxiliary	1,00	95	0,72	0,52
		3	Semi-quick	1,75	167	0,97	0,52
		4	Quick	2,70	257	1,08	0,90
		5	Triple crown	3,50	333	1,35	1,80
		10	Dual	4,50	429	i 0.72 / and 1.02	i 0.46 / and 0.66
	III	6	Auxiliary	1,10	105	0,73	0,52
		7	Semi-quick	1,75	167	0,98	0,52
		8	Quick	3,00	285	1,26	0,90
		9	Triple crown	3,80	362	1,35	1,80
	AE	11	Auxiliary	1,00	95	0,72	0,52
		12	Semi-quick	1,75	167	0,97	0,52
		13	Quick	3,00	285	1,32	0,90
		14	Dual gear	5,00	476	i 0.75 / and 1.58	i 0.30 / and 1.40



The appliance is tested for methane gas G20 (2H) at a pressure of 20 mbar. When using with other types of gas it is necessary to replace the burner nozzles, and adjust the minimum flame on the gas taps. For nozzle replacement, proceed as described in the following paragraphs.

### 11.1 Cooker hob nozzle replacement



**IMPORTANT:** Before completing the following operations, always make sure that the appliance is disconnected from the power mains.



1. Remove the grids, remove all flame spreading caps and crowns.
2. Using a 7 mm tube spanner, unscrew the burner nozzles [Fig.7].
3. Proceed with burner nozzle replacement based on the type of gas to be used (table “**Adapting to different types of gasses**”  [Page 31]).
4. Correctly reposition the burner in its seat.



Fig. 7: nozzle replacement



**IMPORTANT:** After adjusting for use with a gas that is different from the initial testing one, replace the label on appliance housing with the one that corresponds to the new gas type.

## 12. Adjustment of the minimum



### Instructions for urban and methane gas

1. Light the burner and bring it to the minimum position.
2. Remove the gas tap knob and turn the adjustment screw [Fig. 8] inside or on the side of the tap rod (depending on the model), until a regular minimum flame is obtained.
3. Re-assemble the knob and verify burner flame stability (when quickly rotating the hand from maximum to minimum position the flame must not shut off).
4. Repeat the operation on all gas taps.

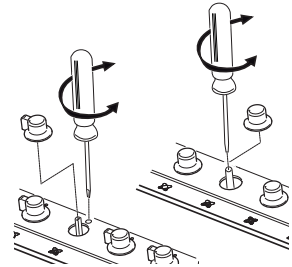

Fig. 8: adjustment of the minimum



### Instructions for liquid gas (LPG)

Tighten the screw inside, or on the side of the tap (depending on the mode), rod clockwise completely.

## 13. Electrical connection of the cooker hob



**IMPORTANT:** Before completing the following operation, always make sure that the voltage and sizing of the power supply line correspond to the characteristics indicated on the plate located under the housing of the appliance. **This plate must never be removed.**



It is mandatory to have an earth connection as per modes foreseen in the electrical system safety standards.

- If using a fixed connection, it is necessary to pre-set an omnipolar interruption device on the appliance power supply line with a contacts distance that is equal to or greater than 3 mm, located in a position that can be reached easily and is in proximity of the appliance.

- If using a connection with a plug and socket, verify that they are of the same type. **Avoid using reducers, adaptors or diverters because they may cause overheating or burns.**



**IMPORTANT:** The manufacturer declines any liability for damages to persons or property, caused by the non observance of the following regulations or resulting from tampering with even a single part of the appliance.

## 14. Cooker hob use

### 14.1 Lighting the burners



Before lighting hob burners, make sure that the flame spreading crowns are positioned in their seat with the respective caps.

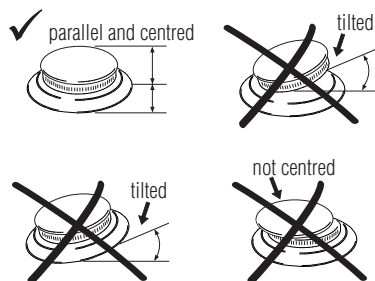

Fig. 9: crown position



The new burners called "Series III" are assembled on certain cooker hobs. The lock system between cover (B) and flame spreading (A) guarantees perfect positioning and large cleaning ability.

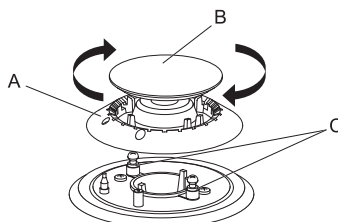

Fig. 10: positioning of the series III burner





The upper cover (B) of the burners must be placed in opposite seat with the two introductions notches in correspondence of the two cylinders below (C) and tighten clockwise.



The associated burner is indicated near each knob. The appliance is equipped with an electric ignition device. It is sufficient to press the knob and rotate it anti-clockwise to the maximum flame symbol, until it is lit. If it does not ignite within the first 15 seconds, bring the knob on ● **[chiuso] (closed)** and do not try to re-ignite for 60 seconds.

Once it is lit, keep the knob pressed for a few seconds in order for thermocouple to heat up. It is possible that the burner shuts off when the knob is released: this means that the thermocouple was not sufficiently heated. Wait a few seconds and repeat the operation, keeping the knob pressed for a little longer. Once the burner is lit, it is possible to adjust the flame based on need.



After every use of the hob, always verify that the control knobs are in ● **[chiuso] (closed)** position.

If the burners were to shut off accidentally, after about 20 seconds a safety device intervenes and blocks gas output, even when the tap is open. In this case bring the knob to ● **[chiuso] (closed)** position and do not try to light the burner for at least 60 seconds.

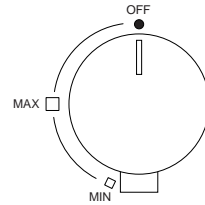

Fig. 11: standard burner knob

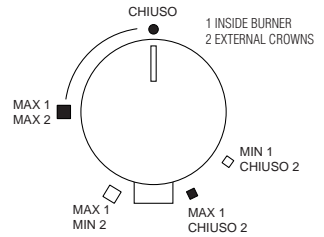

Fig. 12: burner knob dual (S4000)/dual gear

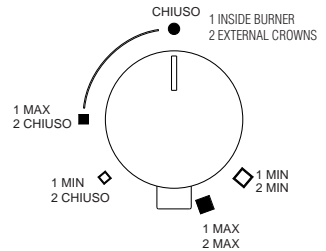



Fig. 13: burner knob dual (GIOTTO/VULCANO)



## 14.2 Practical recommendations for burner use



For better burner yield, and minimum gas consumption, it is necessary to use flat and regular bottom pots, equipped with a cover and proportioned to the burner, in order to avoid that the flame goes up their sides (see the “**Pots diameter**” paragraph  [Page 36]). When boiling, reduce the flame as much as needed to make sure that the liquid does not overflow.

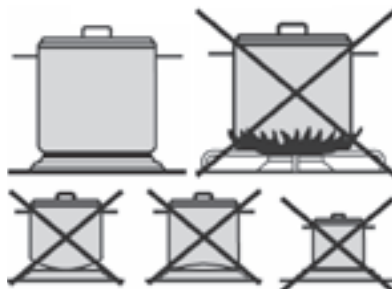



Fig. 14: pots use



During cooking, all containers or steak pans, also to avoid burns or damage to the hob, must not exceed the measurements indicated in the paragraph “**Pot diameter**”  [Page 36]). Do not heat empty pots or pans, because they may overheat.



When using greases or oils, pay careful attention because, when overheating, they may catch on fire. If a pan containing greases or oil catches on fire, do not pour water on it because it may cause burns; extinguish the fire by covering the pan with a wet cloth and disconnect the appliance from the power mains.

## 14.3 Pot diameter

- Auxiliary burner: from 6 to 14 cm
- Semi-quick burner: from 15 to 20 cm
- Quick burner: from 21 to 26 cm
- Double crown, triple crown, dual burners: from 24 to 28 cm



During operation, the cooker hob generates heat and humidity in the room it is installed in. Make sure that the kitchen is well ventilated. A prolonged use of the appliance with some or all burners may require additional ventilation such as opening a window and/or a greater suction power from the exhaust hood.



## 15. Cleaning and maintenance



Do not use a steam jet to clean the appliance.

Before any intervention it is necessary to disengage the appliance power supply.

Avoid leaving acid or alkaline (vinegar, lemon juice, salt, tomato juice,...) substances on the steel, grids and other parts of the appliance.

### 15.1 Cleaning the stainless steel

In order to properly preserve the stainless steel, it is necessary to regularly clean it after each use, once it has cooled down.

#### 15.1.1 Daily ordinary cleaning

In order to clean and preserve stainless steel surfaces, only use specific products that do not contain abrasives or chlorine based acid substances.

Usage mode: pour the product on a wet cloth and pass it over the surface, carefully rinse and dry using a soft cloth or a deerskin.

#### 15.1.2 Food stains or residue



Absolutely avoid using metal sponges and sharp scrapers to avoid damaging the surfaces. Use normal products for steel, non abrasives, using wood or plastic material tools if needed. Carefully rinse and dry using a soft cloth or a deerskin.

We recommend using Foster Steel Clean to clean the steel; for information on where it can be obtained, contact the after-sales technical assistance centre.

Do not use chemical detergents such as oven sprays or stain removers.

### 15.2 Cleaning gas components

The grids, caps and flame spreading crowns are removable in order to simplify cleaning: wash them in hot water with non abrasive detergent, making sure that any crud is removed and dry them immediately using a cloth. Re-assemble the caps on their crowns. The cast iron components, like the grids and the burners, must never be washed in dishwashers.





For the ignition glow plugs to work correctly, the thermocouples must always be clean. Frequently check them and, if necessary, clean using a wet cloth and then dry them. Any dry residue must be removed using a wood toothpick or a needle.





Foster S.P.A. will not answer for the possible inaccuracies contained in this manual attributable to printing or transcription errors. The right is reserved to make amendments to own products considered necessary or useful, also in the interest of the utility, without jeopardising its functional and safety features.

## Riepilogo piani cottura a gas



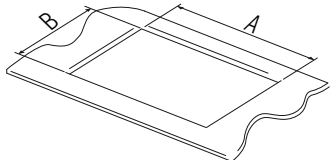

Legenda			
Serie	N.	Brucciatore	Potenza (W)
	1	Manopola di comando	
II	2	Ausiliario	1.000
	3	Semirapido	1.750
	4	Rapido	2.700
	5	Tripla corona	3.500
	10	Dual	4.500
III	6	Ausiliario	1.100
	7	Semirapido	1.750
	8	Rapido	3.000
	9	Tripla corona	3.800
AE	11	Ausiliario	1.100
	12	Semirapido	1.750
	13	Rapido	3.000
	14	Doppia corona	5.000



Tipo di bordo	
Bordo standard (8 mm)	
Bordo Q4 (4 mm)	
Bordo semifilo (3 mm)	
Bordo filotop	

Fori da incasso		
		
 <p>A = larghezza - B = profondità</p>		

## Gas cooker hobs summary

Key			
Series	No.	Burner	Power (W)
	1	Control knob	
II	2	Auxiliary	1.000
	3	Semi-quick	1.750
	4	Quick	2.700
	5	Triple crown	3.500
	10	Dual	4.500
III	6	Auxiliary	1.100
	7	Semi-quick	1.750
	8	Quick	3.000
	9	Triple crown	3.800
AE	11	Auxiliary	1.100
	12	Semi-quick	1.750
	13	Quick	3.000
	14	Dual gear	5.000

Edge type	
Standard edge (8 mm)	
Q4 edge (4 mm)	
Semi-flush edge (3 mm)	
Flush-mount edge	

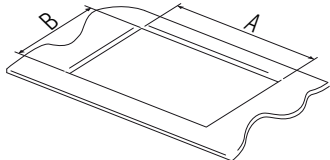
Holes for built-in		
		
 <p>A = width - B = depth</p>		

# 1.1 4000

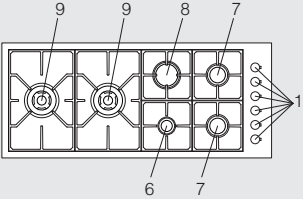
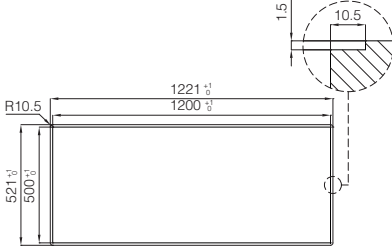
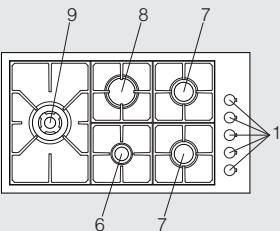
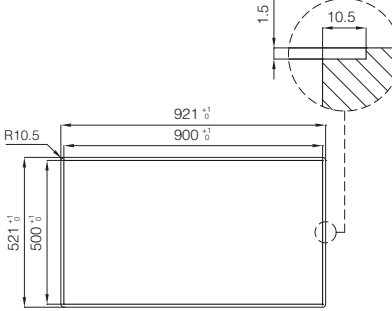
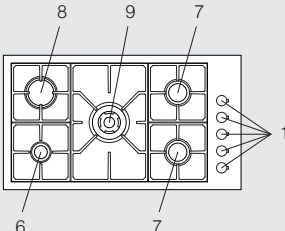
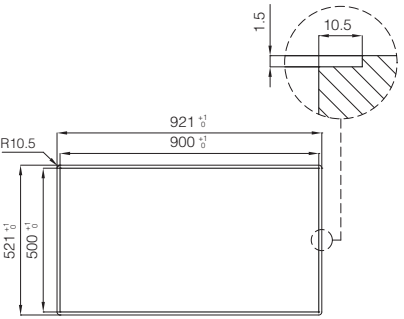
 <p>Top view of the N7272V control panel. It features a 2x4 grid of burner positions. Callouts 6 and 7 point to the bottom row of burners, 8 and 9 to the top row, and 1 to a group of five small burners on the right side.</p>	<p><b>Q4</b> N7272V</p> <p>A = 1160 mm B = 480 mm</p>	<p><b>FT</b> N7272V</p>  <p>Front view of the N7272V control panel. Dimensions include a total width of 1221 mm (with a 1200 mm section), a total height of 521 mm (with a 500 mm section), and a radius of R10.5. A detail view shows a 10.5 mm wide section with a 1.5 mm height.</p>
 <p>Top view of the N7252V control panel. It features a 2x3 grid of burner positions. Callouts 6 and 7 point to the bottom row, 8 and 9 to the top row, and 1 to a group of five small burners on the right side.</p>	<p><b>Q4</b> N7252V</p> <p>A = 860 mm B = 480 mm</p>	<p><b>FT</b> N7252V</p>  <p>Front view of the N7252V control panel. Dimensions include a total width of 921 mm (with a 900 mm section), a total height of 521 mm (with a 500 mm section), and a radius of R10.5. A detail view shows a 10.5 mm wide section with a 1.5 mm height.</p>
 <p>Top view of the N7270V control panel. It features a 2x3 grid of burner positions. Callouts 6 and 7 point to the bottom row, 8 and 9 to the top row, and 1 to a group of five small burners on the right side.</p>	<p><b>Q4</b> N7270V</p> <p>A = 860 mm B = 480 mm</p>	<p><b>FT</b> N7270V</p>  <p>Front view of the N7270V control panel. Dimensions include a total width of 921 mm (with a 900 mm section), a total height of 521 mm (with a 500 mm section), and a radius of R10.5. A detail view shows a 10.5 mm wide section with a 1.5 mm height.</p>

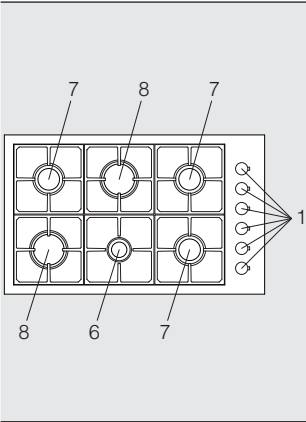

**Q4**  
N7253V

A = 830 mm  
B = 480 mm

**FT**  
N7253V

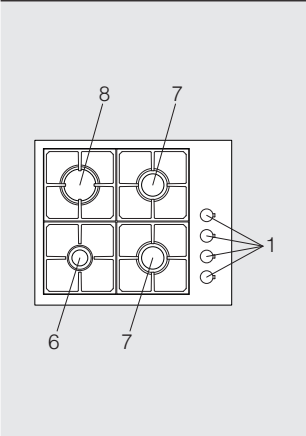
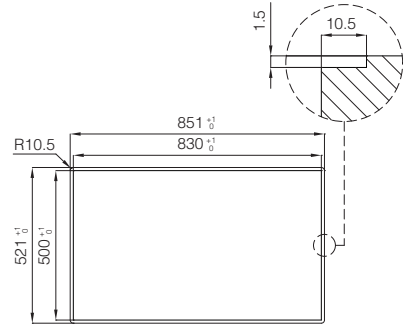

**Q4**  
N7251V

A = 560 mm  
B = 480 mm

**FT**  
N7251V

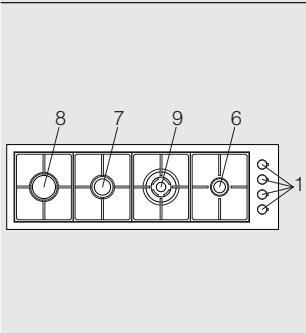
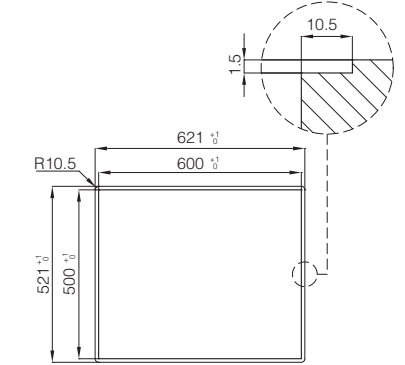

**Q4**  
N7254V

A = 1159 mm  
B = 348 mm

**FT**  
N7254V

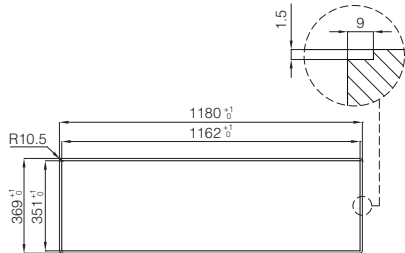

**SF**  
N7254V

A = 1162 mm  
B = 351 mm

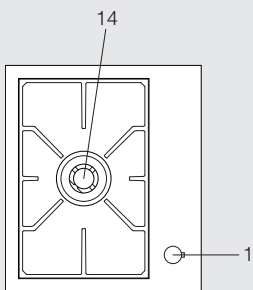

 N7278V-AEO

A = 430 mm

B = 480 mm

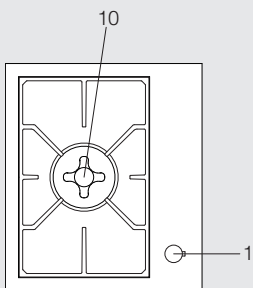

 N7277V

A = 430 mm

B = 480 mm

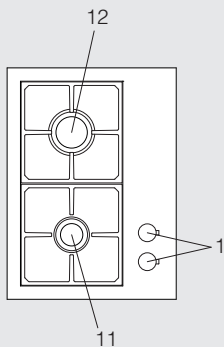

 N7276V-AEO

A = 360 mm

B = 480 mm

## 1.2 QUADRA

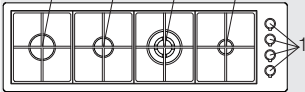
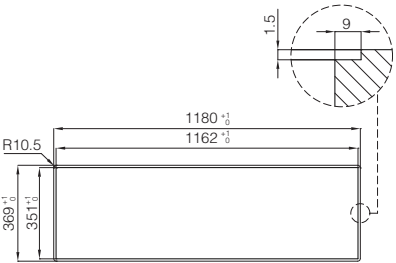
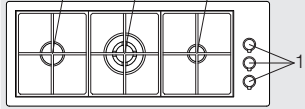
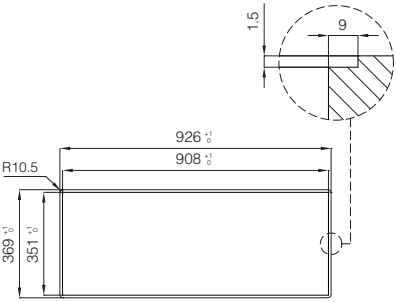
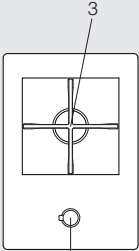
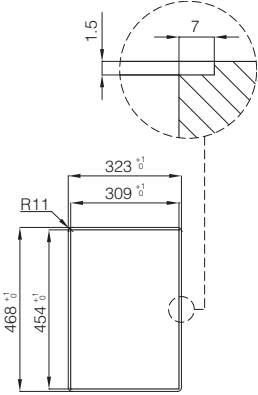
	<p><b>SF</b> N7215V</p> <p>A = 1162 mm B = 351 mm</p>	<p><b>FT</b> N7214V</p> 
	<p><b>SF</b> N7211V</p> <p>A = 862 mm B = 351 mm</p>	<p><b>FT</b> N7211V</p> 
	<p><b>SF</b> N7221V</p> <p>A = 309 mm B = 454 mm</p>	<p><b>FT</b> N7221V</p> 



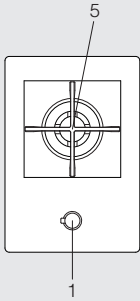

SF N7223V

A = 309 mm  
B = 454 mm

FT N7223V

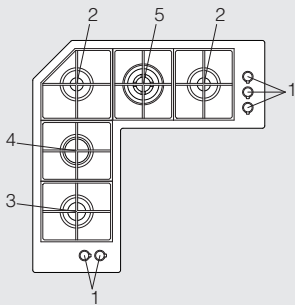
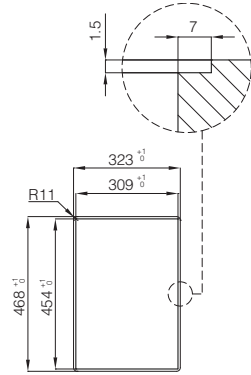

SF N7238V

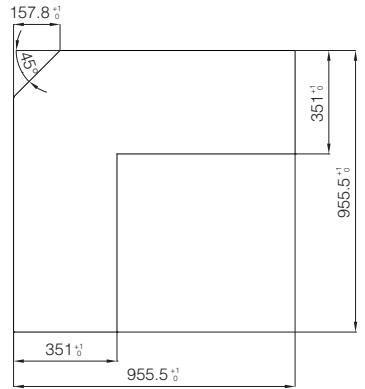

FT N7238V

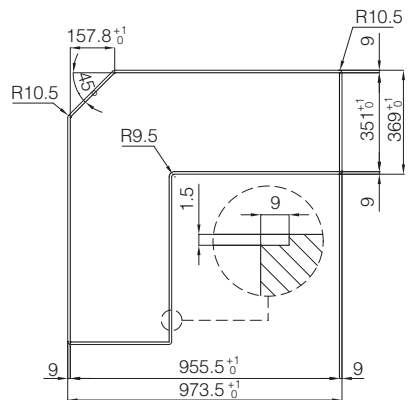







### 1.3 KE

	<p>STD N7603VKE</p> <p>A = 840 mm B = 480 mm</p>	<p>FT N7600VKE</p>
	<p>STD N7600VKE</p> <p>SF N7600VKE</p> <p>A = 770 mm B = 480 mm</p>	

### 1.4 KS

	<p>STD N7610V</p> <p>A = 770 mm B = 480 mm</p>	
	<p>STD N7615V</p> <p>A = 560 mm B = 480 mm</p>	

# 1.5 PROFESSIONALE

	<p>  STD   SF         </p> <p> <b>N7055V-10</b>  <b>N7055V-10</b> </p> <p>           A = 840 mm            B = 480 mm         </p>	<p>  FT  <b>N7055V-10</b> </p>
	<p>  STD   SF         </p> <p> <b>N7053V-10</b>  <b>N7053V-10</b> </p> <p>           A = 560 mm            B = 480 mm         </p>	<p>  FT  <b>N7053V-10</b> </p>
	<p>  STD         </p> <p> <b>N7062V-08</b> </p> <p>           A = 270 mm            B = 480 mm         </p>	

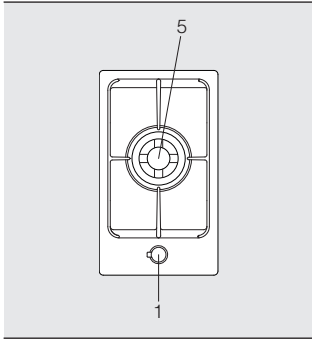

STD  
N7061V-08

A = 270 mm  
B = 480 mm

## 1.6 LISA

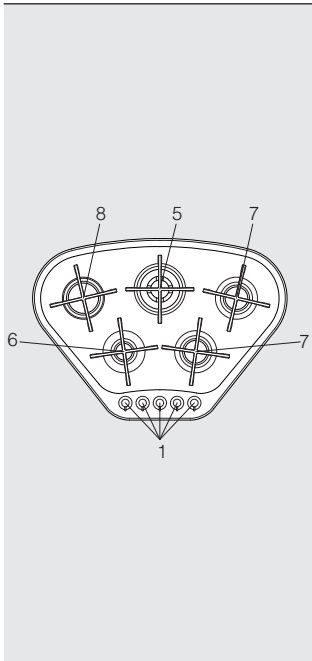

SF  
N7290V

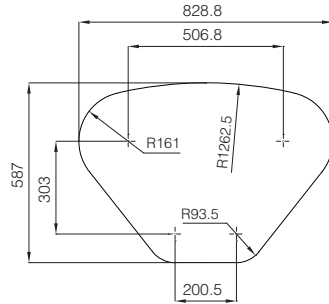

FT  
N7290V

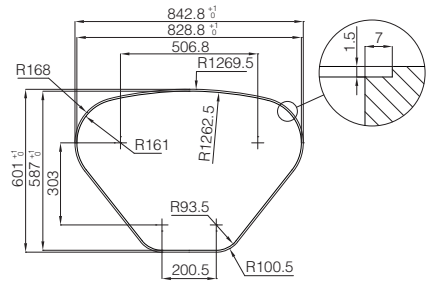

## 1.7 FAUST

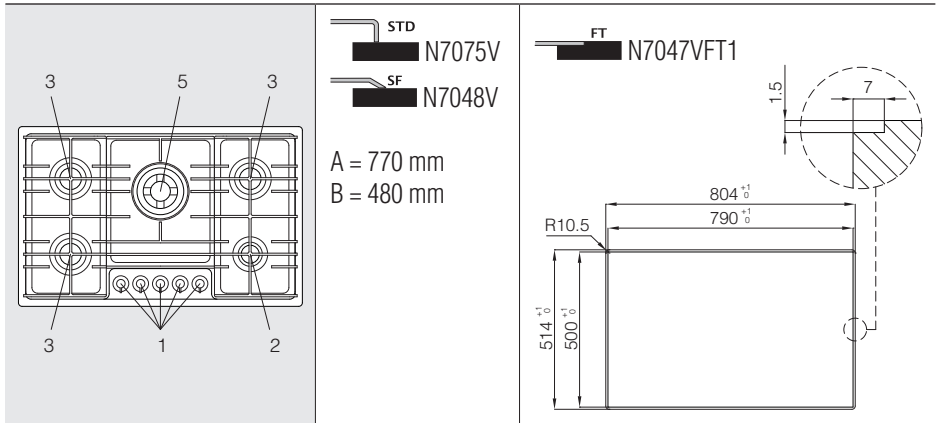

## 1.8 ELEONORA

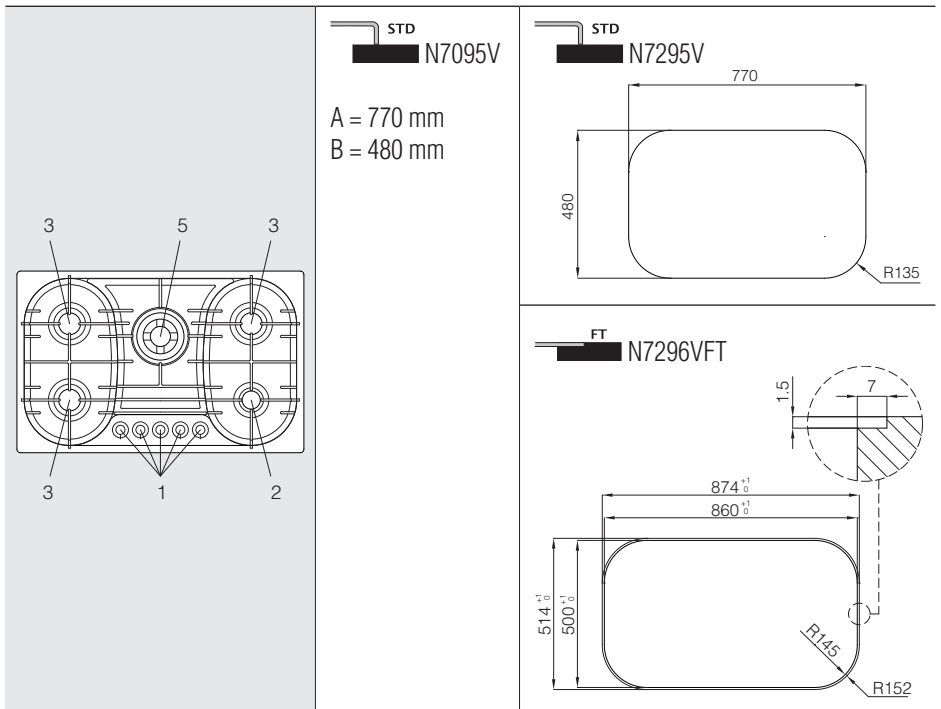

## 1.9 VULCANO

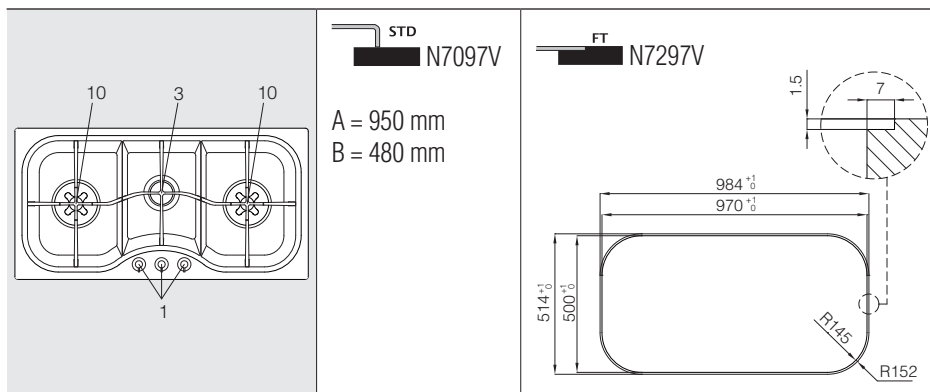

## 1.10 VERONIKA

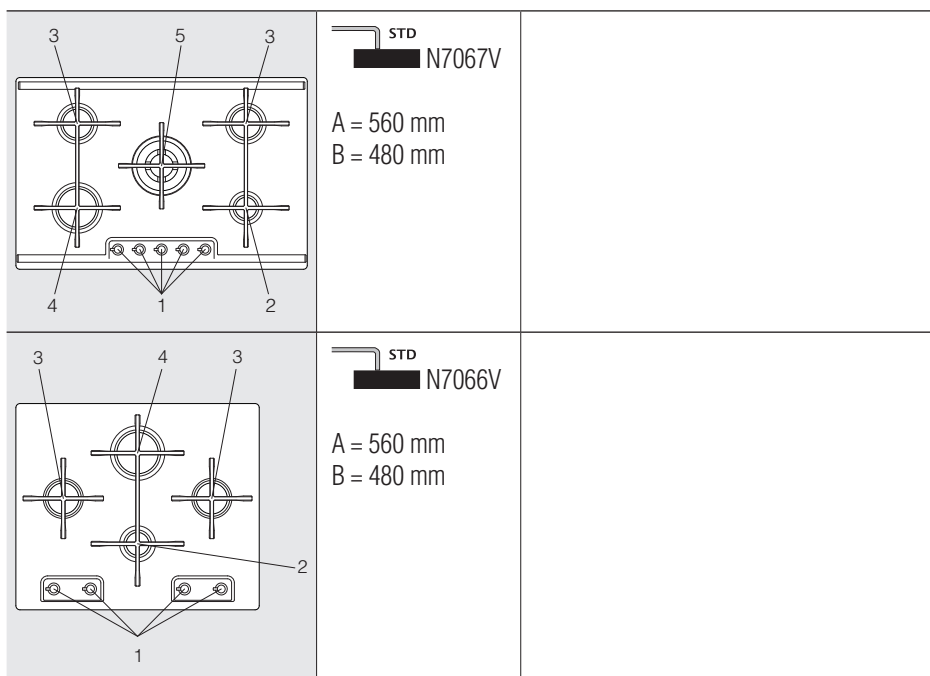

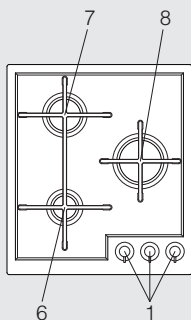

STD  
N7063V

A = 420 mm  
B = 480 mm

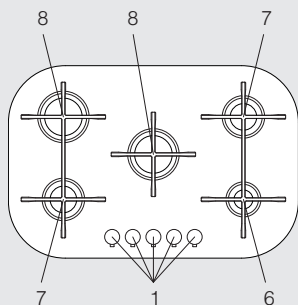

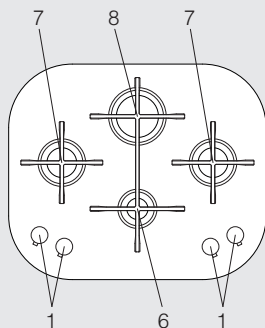
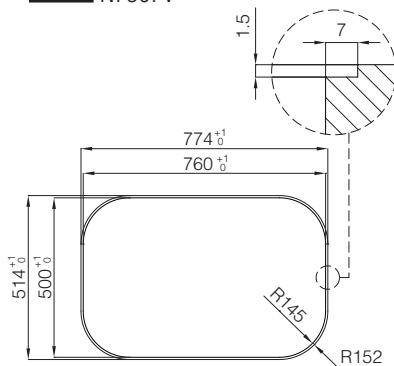

FT  
N7367V

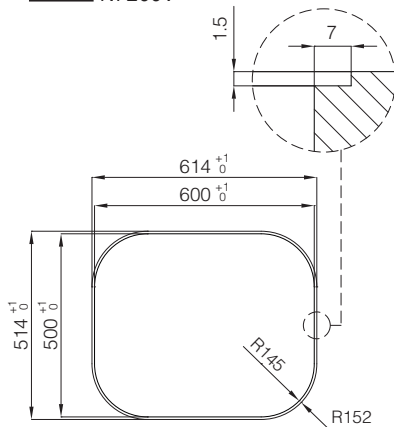

FT  
N7266V



## 1.11 ELETTRA - PANDORA

	<p>  N7064V            A = 560 mm            B = 480 mm         </p>	
	<p>  N7065V            A = 560 mm            B = 480 mm         </p>	

## 1.12 MAGIC

	<p>  N7024V            A = 740 mm            B = 480 mm         </p>	<p> </p>
--	--	----------



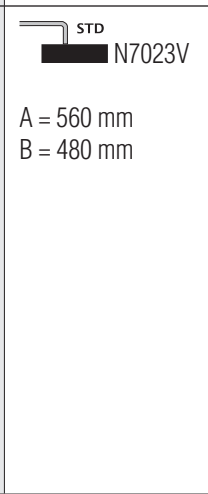
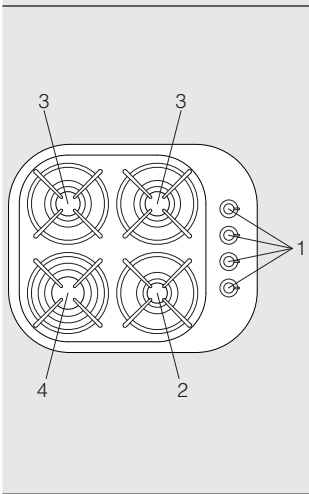
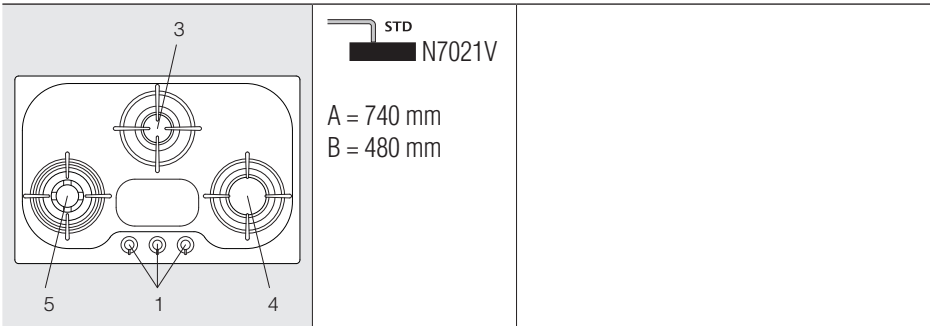

### 1.13 ALIEN

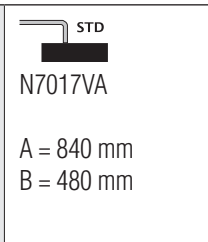
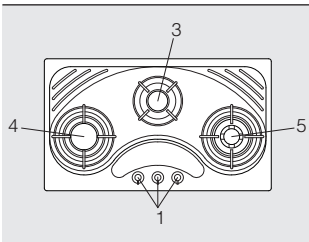

## 1.14 ANGOLARE

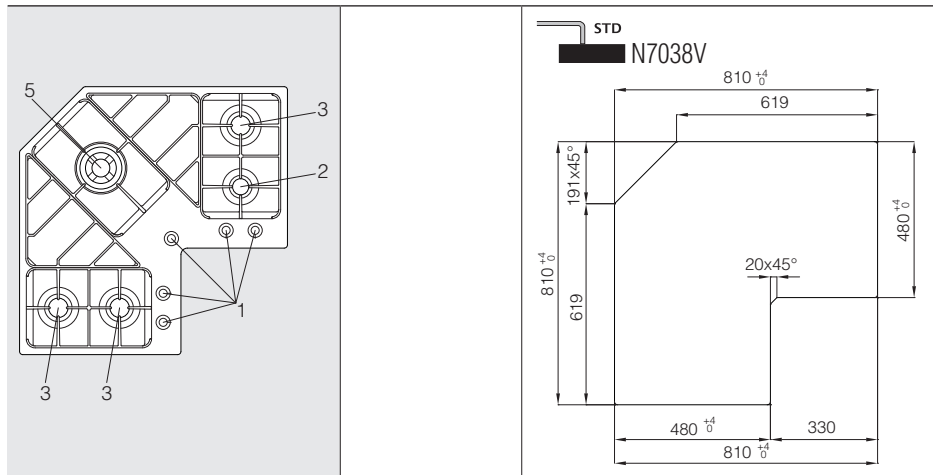

## 1.15 F2000

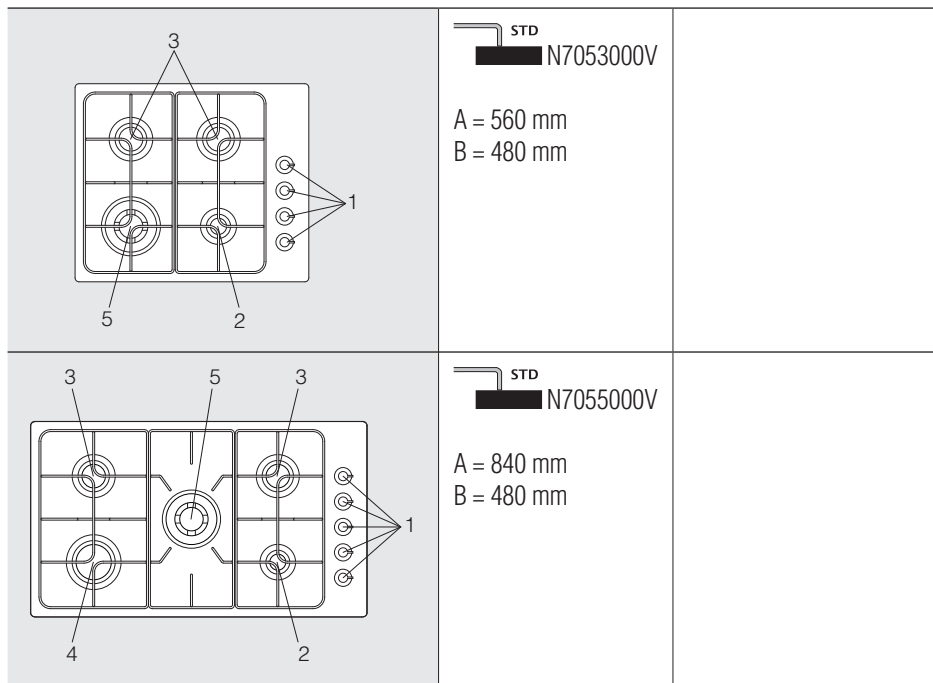

## 1.16 RONDÒ - GIOTTO

	<p>STD N7052V</p> <p>Ø 500 mm</p>	
	<p>STD N7051VG</p> <p>Ø 500 mm</p>	

## 1.17 ALFA

	<p>STD N7260V</p> <p>SF N7260V</p> <p>A = 840 mm B = 480 mm</p>	<p>FT N7260V</p>
--	---	----------------------